

# Fast Bus Transfer Systems – A System Solution Approach

Amit Rajе, *Member, IEEE*, Anil Rajе and Arvind Chaudhary, *Senior Member, IEEE*

**Abstract**— A Bus Transfer System (BTS) is designed to provide process continuity to the loads attached to a motor bus while transferring the bus from one source to another. A successful bus transfer under contingent conditions provides immense value and benefits to continuous process operations that cannot afford an interruption of power supply to plant auxiliaries. This paper describes some real-world bus transfer requirements and implementations in power plants and continuous process industry plants. Emerging trends such as use of Generator Circuit Breakers (GCB), new switchgear configurations, islanded captive power generation and their impact on bus transfer system requirements are analyzed. A systems solution approach rather than a product-based approach is emphasized to meet the overall technical bus transfer requirements.

**Index Terms**— Bus Transfer System (BTS), Automatic Bus Transfer (ABT), Continuous Process, Fast, In-Phase, Residual Voltage, Islanding, Generator Circuit Breaker, System Solutions.

## I. INTRODUCTION

A Bus Transfer System (BTS) is designed to provide process continuity to the loads attached to a motor bus while transferring the bus from one source to another. Such systems find immense use and importance in several critical situations in continuous process industries (petrochemical plants, chemical plants, semiconductor manufacturing plants, paper mills, textile mills, etc.) and fossil-fuel-fired as well as combined cycle gas turbine plants & nuclear power generation stations. The BTS directly contributes to saving revenue loss, avoiding large capital losses associated with material wastage on a break in process continuity, and avoiding large operation and maintenance costs and delays associated with process restarts. A BTS also safeguards against potential safety hazards that relate to sudden process interruptions.

Bus transfer is best appreciated by virtue of its automatic operation on the contingency of the old source currently servicing the plant motor load, such that the old source gets disconnected from the motor bus, and the healthy alternate available source gets connected to the motor bus. Such an

action that avoids the loss of process continuity is extremely desirable, provided it does not compromise the safety features of the entire system.

Bus transfer has been employed in various power generation and process industry scenarios using different philosophies and methods. Considerable research and survey work has been done in the field in the past [1] [2]. Traditionally, bus transfer has been included in the switchgear package of a typical medium voltage installation for power generation utilities and continuous process industries. However, its sphere of influence transcends the electrical systems of the plant, because the efficacy of a BTS directly affects the operations, revenue and short-term as well as long-term performance parameters of the plant.

A bus transfer operation reflects on three vital parameters of the plant from the operation and maintenance (O&M) point of view: the duration of open-circuit condition of the motor bus, the electrical and mechanical stress endured by the motors and associated equipment during the bus transfer, and the blocking of the BTS during a short circuit condition at the motor bus. While the first parameter decides the speed with which power feed is restored for plant operations, the second and third parameters affect the safety and reliability aspects of the plant. These considerations merit an in-depth understanding and judicious implementation of such systems.

## II. BUS TRANSFER CONFIGURATIONS AND NEW REQUIREMENTS

A BTS is typically employed in several different switchgear configurations. Some such configurations and special requirements encountered by the authors, including popular configurations such as the Main-Tie and the Main-Tie-Main schemes, are detailed here.

### A. Main-Tie (2-Breaker Scheme)

The 2-breaker scheme is employed to service a single motor bus from two alternate sources. The normal source feeds the motor bus through the Main breaker, while the alternate source feeds the motor bus through the tie breaker.

A typical example is that of a thermal power plant, where the unit auxiliaries, such as boiler feed pumps, forced draft and induced draft fans, cooling water pumps, etc., are supplied through unit boards. The configuration in Fig. 1 shows a single unit board, although higher capacity units typically have two or more unit boards.

The unit board can be fed from two sources. The Unit Auxiliary Transformer (UAT) (normal source) supplies locally generated power to run the auxiliaries when the unit incoming breaker (UAT I/C) is closed. The station board

---

Manuscript received July 10<sup>th</sup>, 2008.

Amit Rajе is with Aartech Solonics Limited, E-2/57, Arera Colony, Bhopal, Madhya Pradesh, 462016 India (phone: +91-755-2463593, +91-9993091164 ; tel/fax: 91-755-4276335; e-mail – amitraje@aartechsolonics.com ).

Anil Rajе is with Aartech Solonics Limited. (email: aaraje@aartechsolonics.com)

Arvind Chaudhary is with the Protective Relays Group of Cooper Power Systems (email: Arvind.Chaudhary@CooperIndustries.com).

978-1-4244-1762-9/08/\$25.00 ©2008 IEEE

(alternate source) supplies power to the auxiliaries from the grid when both tie breakers (TIE-1 and TIE-2) are closed, and UAT I/C is open.

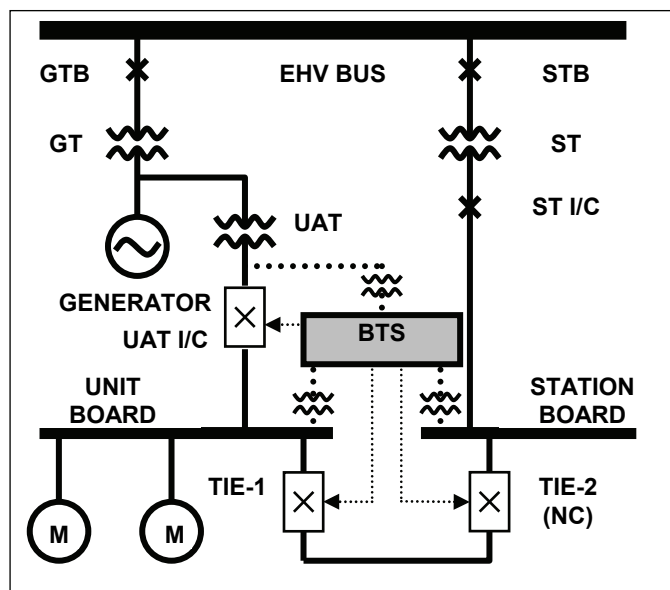

Fig. 1. Thermal power plant: Main-Tie BTS configuration.

During startup, the generator transformer breaker (GTB) is open until the generator is synchronized with the grid. Until then, the station board supplies the unit board. After the generator is synchronized, the unit board is transferred to the UAT so that the unit feeds its own auxiliaries. Such a transfer is referred to as a Station-to-Unit transfer. There are several prioritized and categorized unit tripping conditions such as generator trip, load throw off, turbine trip, boiler trip etc. along with UAT / GT transformer trips on differential, winding temperature, oil temperature etc. under which it is required to automatically transfer the unit board from the UAT to the station board. These transfers are referred to as Unit-to-Station transfers. Automatic transfers on unhealthy bus conditions determined by different auto-initiation criteria are also employed in order to constantly provide a healthy supply to the motor bus. Manual transfers are commonly conducted during planned start-ups and shutdowns.

Typical breaker-failure logic safeguards the unit board from a permanent paralleling condition. TIE-2 is a normally closed (NC) breaker, used as a backup measure to safeguard the unit from a dangerous generator back-feed condition, in case both TIE-1 and UAT I/C fail to open.

### B. Main-Tie-Main (3 Breaker Scheme)

Fig. 2 shows a 3-breaker scheme employed to service two motor buses from two alternate sources. Each source feeds a single motor bus through its main incoming breaker. A tie breaker is provided for coupling the two motor buses.

A typical example is that of a process industry, serviced by two separate stations SOURCES I and II, each capable to meet the load on both the Buses I & II, off the grid. The SOURCE I transformer is connected through I/C - I incoming breaker to BUS I.

Similarly, SOURCE II transformer is connected through I/C - II incoming breaker to BUS II. BUS I and BUS II are connected using the TIE breaker. There are several bus transfer scenarios depending upon the choice of the normal supply to the motor buses.

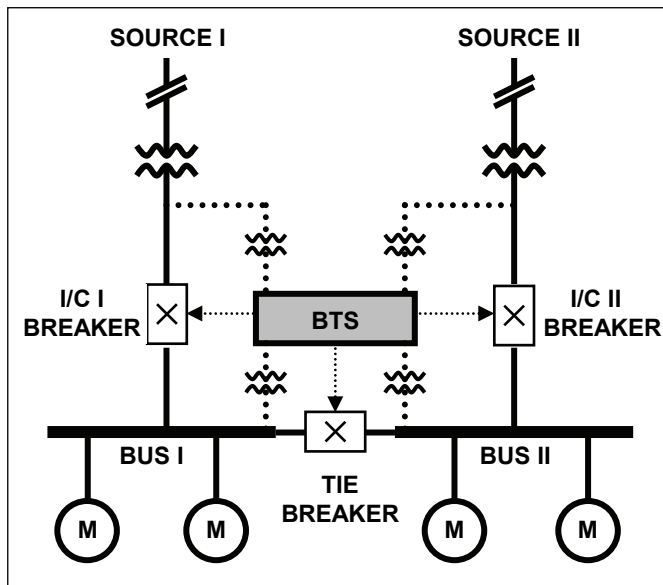

Fig. 2. Process industry: Main-Tie-Main BTS configuration

1) *Normally closed TIE breaker:* The entire motor bus comprising BUS I and BUS II is transferred between SOURCE I and SOURCE II.

2) *Normally open TIE breaker:* Each source supplies power to a single motor bus. In case of source failure, the motor bus connected to the failed source is transferred to the source through the TIE breaker.

Since process continuity is the prime consideration in industrial plants, automatic transfers determined by different auto-initiation criteria for source contingencies as well as source equipment failure conditions are employed. Manual transfers are commonly conducted during planned start-ups and shutdowns. Typical breaker-failure logics safeguard the motor buses from a permanent paralleling position.

### C. New Bus Transfer System Requirements

#### 1) Introduction of Generator Circuit Breaker

Introduction of Generator Circuit Breaker (GCB) provides the important benefit of eliminating the bus transfer requirement in case of unit tripping conditions as the GT can back-charge the unit board in such conditions. However, under conditions such as GT trip or UAT trip on differential, winding temperature, oil temperature, or auto transfer conditions to detect upstream source failures - an automatic fast transfer is still required to constantly provide a healthy supply to the motor bus. Manual transfers are also commonly conducted during planned start-ups and shutdowns where there is an option now available to charge the unit board by back-charging (through the GT/UAT) or the station board. Several such schemes are now successfully commissioned in thermal and nuclear power generation installations.

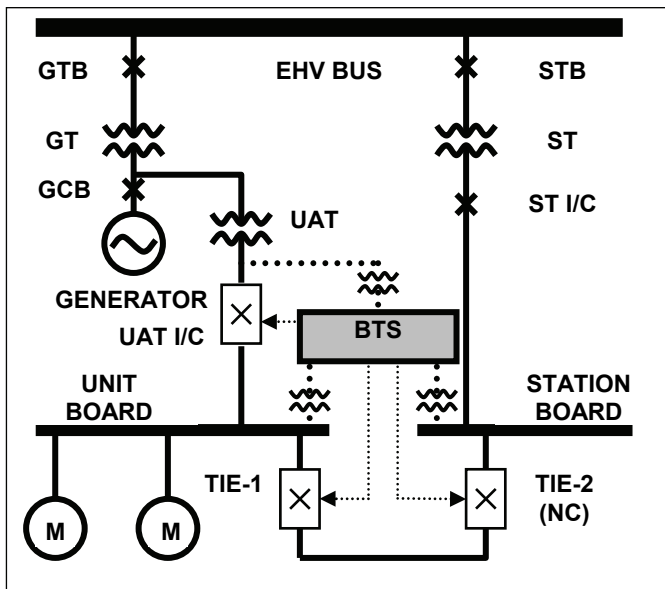

Fig. 3. Thermal power plant with GCB: Main-Tie BTS configuration.

2) Deregulation, UAT sizing, Distribution of Loads and Bus Transfer

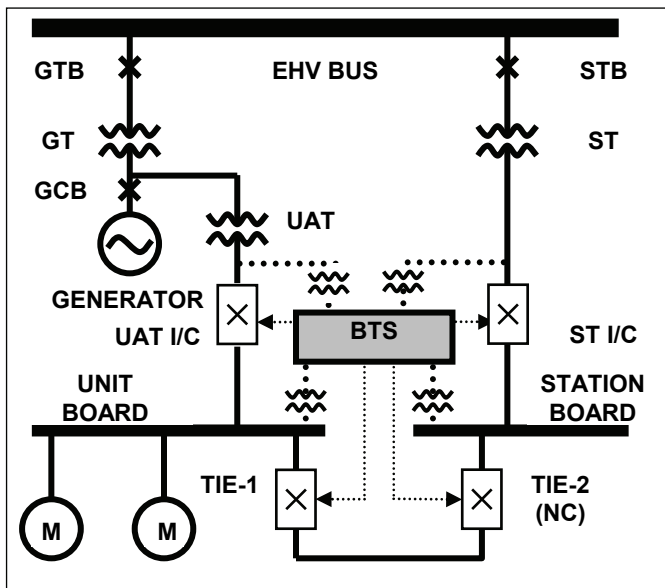

Fig.4. Thermal power plant with GCB and UAT sized to take station board load: Main-Tie-Main BTS configuration.

Due to deregulated scenario in the power sector, significant differential tariffs are now applicable on the unit board load whether consumed through the UAT (at cost to the GENCO) or through the station board (at grid purchase price from the TRANSCO). This brings more attention on the need to maintain unit board loads from the UAT at all times with the facility of bus transfer to ensure healthy supply to the motor bus at times of unit tripping.

UAT sizing considerations and distribution of loads between unit and station boards are also being revisited in this

light. Originally, UAT sizing was considered purely on the basis of the unit board loads. Two recent 1x250 MW projects now employ designs wherein the UAT is sized to cater to entire unit board + station board loads. Even at the incidence of higher initial capital cost, the system can now operate even its station loads through the unit (at cost to the GENCO) and only in case of unit source failure, it is required to transfer the entire set of 'unit + station' boards from the UAT to the ST. To provide for the entire flexibility of bus transfers in this case, a Main-Tie-Main / 3 Breaker Scheme / Unit-to-Station & Station-to-Unit scheme, as they are sometimes referred to, is used as shown in Figure 4.

3) Islanded Turbine Operation at House load

An islanded transfer has the capability to transfer between two asynchronous sources, such as the co-generation unit and the grid or an islanded turbine operation, while maintaining process continuity.

In the case of an islanded turbine operation, modern turbines are able to sustain operations at house load for a few hours. This feature is especially pertinent during grid failure conditions and their recovery/restoration. During this system, the grid/station board and the unit board sources are asynchronous with respect to each other.

In the instance of a contingency of a turbine trip during such operations, or a planned load transfer of the unit board to the station, the islanded transfer can use the IN PHASE mode to trip the incoming breaker coming from the unit auxiliary transformer and send an advanced closing command to the station tie breaker, so that it closes at the zero-crossing instance of the slip between the grid and the unit board. It is worthwhile to note here that such a transfer is not possible using the fast method of transfer, as it is not recommended to perform a fast transfer between two non-synchronous sources or equivalent.

Thus, the real advantage of the turbines now capable of islanded house load operations can be most advantageously used with such an islanded transfer operation capability.

4) Islanded Transfers with Co-Generation Plant

Consider the case of a plant with a co-generation unit that prefers to operate in isolation from the grid, using its co-generation unit for economy, reliability, or regulation considerations. While the incentive for a co-generation unit to tie to the grid is to earn from the export of power, it is challenging to isolate the plant from the grid in the event of a grid contingency by means of a sophisticated islanding system, especially in the case of weak grids, complex distribution systems and with peaky load conditions / power flows. Thus a grid failure, which may be frequent, automatically results in loss of expensive plant processes.

Alternately, consider the case of islanded operation of a plant with islanded transfer capability, wherein a co-generation unit feeds all the critical auxiliaries. Thus the grid may not be in sync with the co-generation, with independent frequency and voltages, resulting in continuous slip cycles between the two. In the instance of a considerably infrequent contingency of the co-generation unit, the islanded transfer

uses the in-phase mode to trip the incoming breaker coming from the co-generation unit and send an advanced closing command to close the grid incoming breaker at near phase coincidence.

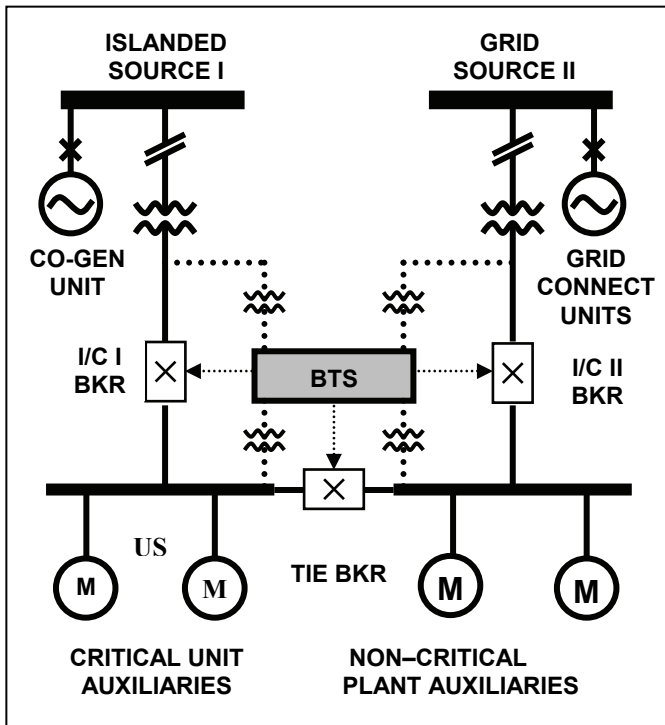

Fig. 5. Islanded Transfers with Co-Generation Plant

Thus the grid can serve only as a backup measure while reliable operations of the plant and its power situations are significantly within the controls of the plant operation. In several cases with several generators as shown in Fig. 5, it is prudent to supply all the critical unit auxiliaries through an islanded captive generator, while other generators and loads in the plant are connected to the grid at all times. Integrated process plants with co-generation find such schemes of great utility.

5) *Grid connection requirements from Transco*

Various process industries owning small captive power units face the problem that although they may be employing a GCB, they are not permitted to back-charge their unit board from the GT/UAT due to TRANSCO stipulations allowing the interconnects to EHV grid to inject power only, and not draw power from the EHV grid. The station source tapped from a MV grid may not be as reliable as the EHV grid, and licensing a separate station transformer from the EHV grid is expensive and redundant for such industries. Alternately, a co-generation unit primarily provided to feed nominal plant load may not be allowed to feed into the MV grid. Special bus transfer scheme configurations are required to be devised in such situations in a customized manner.

In one instance, as shown in Fig 6, the unit auxiliary board was directly fed from the co-generation unit through a GCB, while other plant boards were connected through several bus ties with one end connected to the grid and the other end

provided with a tie to the unit board. A proposed bus transfer scheme does a transfer between the unit tie and the GCB, and later more plant boards are disconnected from the grid one-by-one and connected to the unit board which is fed by the generator. Such schemes are being actively considered, especially by industrial customers to mitigate their grid connectivity related problems.

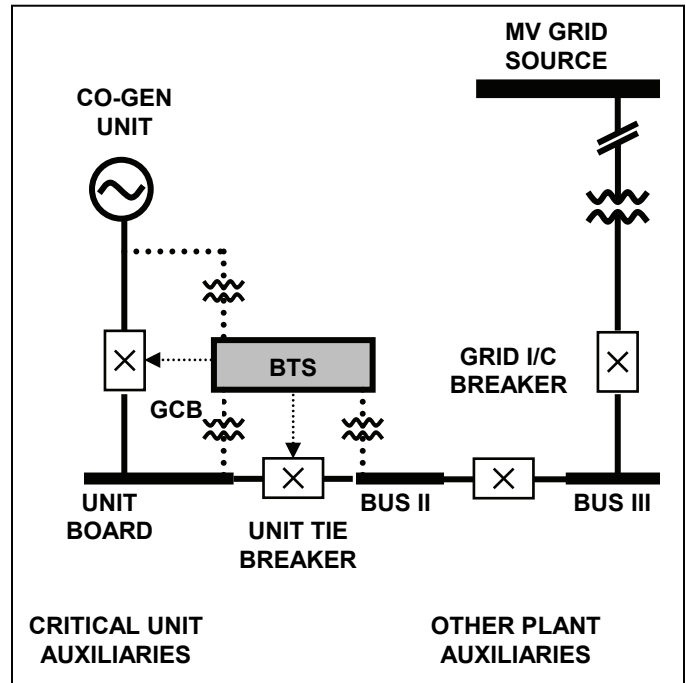

Fig. 6. Bus Transfer involving GCB and Grid Tie

6) *Integrated Load Shedding and Bus Transfer Requirements*

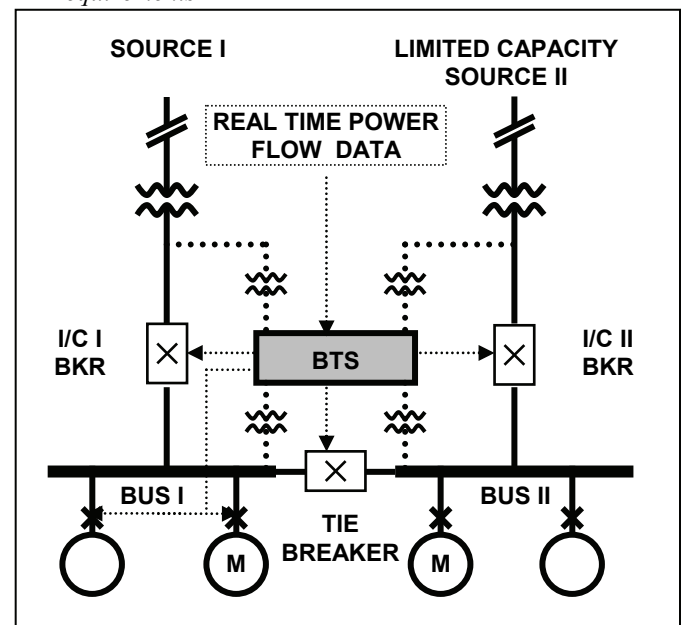

Fig. 7. Bus Transfer with Integrated Load Shedding

Bus transfer may require coordination and integrated load shedding to be carried out if the new source is not able to take

entire bus loads or there are grid imposed power import restrictions. In such cases, real time power flow measurements in the system are coupled with bus transfer logics for issue of optimum load shedding commands in prioritized manner (from low priority to high priority) are required.

In an application, as shown in Fig. 7, real time power flow data is constantly monitored by a bus transfer system. In case of a bus transfer requirement to a source with limited capacity, as established from the real time power flow data, an intelligent prioritized tripping of loads is conducted in coordination with bus transfer with frequency monitoring, to ensure that the new source is not overloaded on bus transfer. A similar scheme has been recently studied for an integrated steel plant application.

#### 7) Distinguishing Source Loss and Source Faults and Process Time Constants

A source loss occurs when an upstream source becomes dead. A source fault on the other hand is when a live upstream source gets faulted. While both cases warrant a bus transfer, the treatment of bus transfer differs. In case of a source loss, the affected bus exhibits spin down characteristics and accordingly auto transfer detection and transfer initiation is required to effect a bus transfer in the earliest possible manner. In case of a source fault, the bus will also get de-energized depending on the nature of the fault. The motors connected to the bus shall also feed the fault till the faulted source is disconnected. When the source breaker is tripped, the bus voltage may also swell momentarily before exhibiting its spin down characteristics. As such the problem of doing bus transfer in case of a source fault is much more challenging, especially in case of very sensitive loads and drives. Depending on the process time constant, intelligent auto transfer criteria, coupled with fast protection, (e.g. sub-cycle protection) interfaced with bus transfer logics or solid state bus transfer systems are necessary to provide such critical solutions. For longer process time-constants, simpler slow transfer schemes with load tripping and re-acceleration schemes may also be feasible.

#### 8) Bridging Power Supply to the Transfer Bus

The open circuit bus transfer is based on the back emf support provided by induction motors to the bus during spin down. Where such support is not available due to load characteristics (or for e.g. extensive use of adjustable speed drives without regenerative support), bridging power supply may be required to provide external support to the bus. As such, capacitors which are commonly employed in several applications for power factor improvement inline with utility requirements also provide reactive support thus helping to maintain the voltage profile during spin down. However, where real power support is required, bridging power supply sources such as synchronous generators, flywheels, batteries, ultra-capacitors may also be considered. The duration, power and energy requirements are critical to size such bridging power supply requirements and the interface is also quite challenging, especially for MV systems. Several such requirements have come to light, especially in industrial

continuous process applications.

#### 9) Retrofitting Slow Bus Transfer Systems

Slow transfer systems employing under-voltage relays and related bus transfer logic are used in a variety of applications, especially provided in the 1980's or earlier. A retrofit of such bus transfer systems with modern microprocessor based fast bus transfer systems offer tremendous value to the customer. Apart from direct advantages related to process continuity, other advantages such as improved health of motors (as observed by significant reduction in maintenance expenses) over a longer period of time have also been observed. Careful application engineering is required to retrofit new systems onto existing switchgear infrastructure and have been successfully engineered and commissioned by the authors for an entire 4x210 MW plant recently.

#### 10) Station-to-Station Scheme

A Station-to-Station scheme typically takes care of a pair of two station boards in a 3 breaker Main-Tie-Main configuration and an automatic fast transfer requirement is often not considered in system designs, although this may be critical in case of important auxiliaries being provided on the station boards.

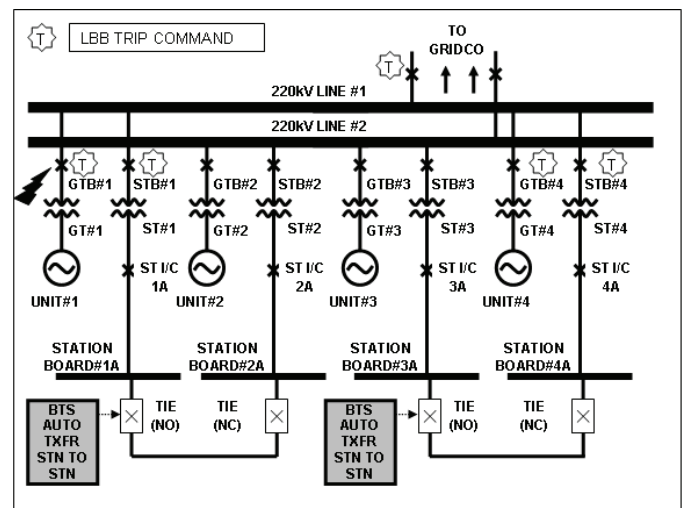

Fig. 8. 4x210 MW Thermal Power Plant – LBB Trip resulting in Unit & Station Board AC Failure

The authors are aware of an exceptional incident where a plant consisting of 4 210 MW units (say Unit#1-4) had 2 units each feeding into separate 220kV lines (say Unit#1,4 – Line#1 & Unit#2,3 – Line#2). This installation was provided with automatic fast transfer schemes only for Unit-to-Station, and Manual-Only schemes for Station-to-Station fast bus transfer. Incidentally, the Station Transformers ST#1,4 for Unit#1,4 were also connected to Line#1, and ST#2,3 for Unit#2,3 were connected to Line#2 which is not a standard practice in the interest of redundancy. Unit#1 was being withdrawn for shutdown, when its Generator Transformer Breaker (GTB#1) mal-operated and did not trip. This resulted in an LBB condition on the Line#1, tripping all the feeds from that line in the plant, which included GTB#4 for Unit#4 (operating at full load) along with STB#1, 4. Protective logics immediately initiated a Unit-to-Station transfer for Unit#1, 4; which



successfully transferred Unit#1,4 unit boards to ST#1,4 respectively.

However, this was not of any use since ST#1, 4 had also lost its incoming feed from Line#1. The backup DG Supply also malfunctioned and failed to startup. Thus both Units#1,4 suffered total AC Failure. Had there been an automatic Station-to-Station Scheme, the station boards fed from ST#1, 4 could have transferred to ST#2, 3 avoiding this condition.

As a matter of fact, Unit#4 suffered station battery bank failures for both its backup DC supply banks due to the sudden surge in load, and the DC Jacking Oil Pump (JOP) also lost supply within a few minutes of this event leading to irreparable damage to its turbine bearings and several months of unit outage. Automatic station-to-station bus transfer schemes are now under consideration for this plant.

#### 11) *Integrated Unit-to-Station + ½ Station-to-Station Schemes*

While a Unit-to-Station scheme typically takes care of bus transfer requirements for a unit board, and a Station-to-Station scheme typically takes care of a pair of two station boards; an integrated Unit-to-Station + ½ Station-to-Station scheme takes care of bus transfer requirements of a pair of 1 Unit Board and 1 Station Board with only marginal limitations compared to the original full fledged schemes such as availability of transfer direction between station incomers.

This scheme however offers significant advantages in terms of economy (per scheme) along with a superior automatic fast bus transfer facility for station boards which is usually not considered in system designs, yet may be critical incase of important auxiliaries being provided on the station boards and other considerations as described above. These schemes were recently implemented and successfully commissioned in a 4x250 MW Mega Power Plant recently.

### III. TYPICAL FEATURE REQUIREMENTS

Irrespective of transfer configurations, a BTS typically has the following feature requirements [4]:

#### 1) *Process Requirements*

- a) Continuity of electrical service to the loads such that operation of the mechanical process system is not disturbed.
- b) Load-shedding should not be required to allow the auxiliary system to reaccelerate.

#### 2) *Electrical Requirements*

- a) Loads should not slow down to the point that large and sustained transient currents are required for motors to reaccelerate.
- b) Excessive transient torques that overstress the motor windings, rotor, shaft, and driven equipment should be avoided.
- c) The BTS should be blocked to operate under a short circuit condition at the motor bus. For a source short circuit condition, parallel bus transfer must be blocked. However, an open circuit of the faulted source bus transfer can be allowed under this condition.
- d) There should be no adverse effects on the protection

system.

#### 3) *System Requirements*

- a) The required controls should be simple to increase overall reliability.
- b) The BTS should automatically operate on contingency detected by external or internal protective elements. The protective elements should provide fast contingency detection, yet be immune to non-contingency system transients.
- c) The BTS should detect any breaker operation failure during bus transfer and take intelligent corrective action to best meet above process and electrical requirements.

### IV. BUS TRANSFER METHODS

The choice of the transfer method plays a critical role in the amount of stress the electrical system may be subjected to during the transfer. The methods differ in the processing, sequencing, and timing related to the closing of the alternate source breaker and the opening of the normal source breaker. The nature of the system dynamic conditions and the nature of the motor loads connected to the motor bus determine the choice of an optimal bus transfer method. The fast transfer method, in-phase transfer method, and the residual voltage transfer method are all open-circuit ‘break before make’ transfers. The momentary paralleling transfer or ‘hot’ transfer is a ‘make before break’ transfer. Details on various bus transfer methods are beyond the scope of this paper, but can be referred to earlier papers [14] [15] by the author.

#### c) *BUS TRANSFER INITIATION*

The need of a bus transfer can be motivated by a variety of reasons. Thus, the means of initiating a bus transfer can be further classified as manual, protective, or auto transfer.

##### *A. Manual Transfer*

Manual transfer is used for planned transfers during startup, shutdown, or certain kinds of maintenance activities of the plant. The actuating mechanisms may be either local or remote using SCADA systems over a communication link. The combination of backup transfer method(s) (e.g. Fast-In Phase-Residual Voltage) is also required to be manually selected before actuation.

##### *B. Protective Transfer*

The protective transfer(s) are initiated automatically on the pickup of different protective relay elements input to the BTS. For instance, a Main-Tie configuration BTS in a thermal power plant has Class A (generator trip, load throw-off) and Class B (turbine and boiler trips) inputs, which actuate immediate changeover of the unit board from the UAT to the station board. Since Class B trips actually cause unit tripping when the reverse power relay operates, corresponding bus transfer can also be suitably coordinated. Similarly, a Main-Tie-Main configuration BTS in a continuous process industry

has incoming source transformer trip and transmission line trip condition logic inputs for protective transfers.

### C. Auto Transfer

Modern microprocessor-based protection systems offer the digital processing capabilities required to do continuous intelligent system monitoring in real-time. Auto transfer initiation logic use these processing capabilities on the bus PT voltage inputs in order to determine the healthiness of the bus. Thus, auto transfer initiation criteria are established based on under-voltage, over-voltage, under-frequency, over-frequency, (df/dt) limits, etc. or many combinations thereof. The ultimate choice of the auto-initiation criteria is determined by the speed and reliability of its response to detect contingencies and its immunity to non-contingency system transients.

## V. BTS INTEGRATED REQUIREMENTS

A complete and integrated BTS solution also needs to meet certain key requirements.

### A. Monitoring BTS Readiness Conditions

Since the BTS performs system critical activities, it is typically recommended to continuously monitor the status of certain system conditions as a precondition to ascertaining its readiness to conduct bus transfer. These usually include:

- a) Breaker Status (52a, 52b consistency)
- b) Valid System Breaker Configuration State
- c) Breaker in Service Condition (75S)
- d) PT Fuse Failure Condition (98X)
- e) PT Cubicle in Service Position (75S)
- f) In Circuit Monitoring of Breaker Trip/Close Circuits
- g) Breaker Over-Current Condition (86A)
- h) New Source Voltage / Frequency Healthiness

### B. Breaker Failure Detection and Corrective Action

A breaker may fail to operate due to electrical and/or mechanical reasons during a bus transfer. This may result in dead bus/permanent paralleling, depending upon the failure of closing of new source breaker or opening of old source breaker respectively. Such a situation may be detected from the monitoring of the breaker NO/NC status inputs (52a, 52b) and/or the current flowing in the old source breaker and the new source breaker.

In the event of a permanent paralleling condition, the recently closed new source breaker is tripped. If this breaker fails to open as well, further upstream breakers may be sent tripping commands. Such an extreme event was experienced by the author (2) in 1982 and resulted in a dangerous generator back-feed condition for a 210 MW thermal power generation unit with a Main-Tie BTS configuration. This consideration needs to be taken into account before deciding on the type of switchgear for backup measures. In this situation, the station tie is preferred to be a breaker rather than an isolator, along with incorporation of corresponding control logic to trip the station tie breaker if both the UAT incoming and TIE breaker do not open on their respective tripping

commands.

In the event of a dead bus condition (failure to close of new source breaker), the bus exhibits spin-down characteristics as discussed earlier. Correspondingly, depending on the detection time for the dead bus condition, it may be possible to re-close the old source breaker (provided it is healthy) in the fast/in-phase/residual voltage mode. The in-phase mode is most likely in this situation, since the phase drift would normally be expected to be significant before new source breaker closure failure is detected. A successful closing of the old source breaker using the in-phase method can keep the bus energized. This can help increase the operator confidence for opting for safer open circuit condition-based fast transfers even for manual/planned bus transfers, wherein parallel transfers were used earlier.

### C. Online Testing

The online testing of the BTS enables the operator to periodically ascertain if all the functions of the BTS are operating healthily. It is also possible to operate, monitor, and consequently report the operation of the respective breaker tripping and closing contacts, after the insertion of a high resistance in series to these contacts during this test mode. This fictitious bus transfer gives the operator the highest degree of confidence, before actuating a planned manual bus transfer under the existing system conditions.

## VI. CONCLUSIONS

The use of a high-speed bus transfer system is very effective and beneficial to mitigate the problems related to the loss of process continuity in power plants and continuous process plants. The availability of an alternative source of supply can be best utilized if a high-speed bus transfer system is used to transfer the motor bus from the normal source of supply to the alternative source, in the event of a contingency of the normal source. This can provide enormous savings in revenue, plant load factor and O&M expenditure in the short term, while reducing motor maintenance in the long term. Customized application engineered system solutions incorporating such high-speed bus transfer technology are proven for providing significant benefits in both utility power plants as well as continuous process industries.

## VII. REFERENCES

- [1] D. L. Hornak and D. W. Zipse, "Automated Bus Transfer Control for Critical Industrial Processes," IEEE Transactions on Industry Applications, Vol. 27, No. 5, September/October 1991, pp 862-871.
- [2] R. D. Pettigrew and P. Powell, "Motor Bus Transfer - A Report Prepared by the Motor Bus Transfer Working Group of the Power System Relaying Committee," IEEE Transactions on Power Delivery, Vol. 8, No. 4, October 1993, pp 1747-1758.
- [3] R. H. Daugherty, "Analysis of Transient Electrical Torques and Shaft Torques in Induction Motors as a Result of Power Supply Disturbances," IEEE Transactions on Power Apparatus and Systems, 101: 2826-2836, August 1982.
- [4] W. G. Bloethe and A. A. Bavishi, "Assessment of the dynamic behavior of auxiliary loads during bus transfer," Proceedings of the American Power Conference, Published by Illinois Institute of Technology, Chicago, IL, USA. vol 56, pt 2, 1994, pp 1273-1278

- [5] S. C. Srivastava, K. N. Srivastava and G. N. Murty, "Transient Residual Voltage Analysis during Isolated Operation of a group of Induction Motor Loads," *Electric Machines and Power Systems*, vol 22 no 2 March-April 1994, pp 289-309.
- [6] S. S. Mulukutla and E. M. Gulachenski, "A Critical Survey of considerations in maintaining process continuity during voltage dips while protecting motors with reclosing and bus-transfer practices," *IEEE Transactions on Power Systems*, Vol. 7, No. 3, August 1992, pp 1299-1305
- [7] NEMA MG-1 Motors and Generators, National Electrical Manufacturers Association, Washington, D.C., 1987.
- [8] ANSI C50.41, Polyphase Induction Motors for Power Generating Stations, New York: American National Standards Institute, 1982
- [9] NEMA MG-1 Motors and Generators, National Electrical Manufacturers Association, Washington, D.C., 1982
- [10] C. C. Young and J. Dunki-Jacobs, "The Concept of In-Phase Transfer Applied to Industrial Systems Serving Essential Service Motors," *AIEE Transactions*, vol. 79, January 1961, pp. 508-518.
- [11] A. Raje, A. A. Raje and A. Chaudhary, "High Speed Motor Bus Transfer," 3rd International R&D Conference on Sustainable Development of Water and Energy Resources, Central Board of Irrigation and Power (CBIP), Jabalpur, India, Feb 2000, pp 57-64
- [12] A. Raje, A. A. Raje and A. Chaudhary, "High Speed Motor Bus Transfer Experiences," SWICON-2000, 5th International Conference on Switchgear and Controlgear, IEEMA, India, Nov 2000, pp 25-34.
- [13] A. Raje, A. A. Raje, J. McCall, A. Chaudhary, "Bus Transfer Systems – Requirements, Implementation and Experiences", IEEE PPIC Conference, Toronto, Canada, June 2002.
- [14] A. Raje, A. A. Raje, J. McCall, A. Chaudhary, "Bus Transfer Systems – Requirements, Implementation and Experiences", IEEE Transactions on Industry Applications, Feb 2003.
- [15] A. Raje, A. A. Raje, A. Chaudhary, "Fast Bus Transfer Systems for Critical Process Continuity", IEEE IAS 2004 PCI-India Conference, Nov 2004.

are driven towards converting techno-entrepreneurship ideas and concepts to practically implement-able products and services for a wide range of industrial applications.

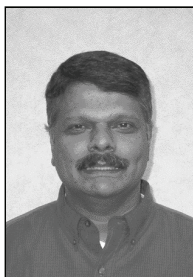

**Arvind Chaudhary** (S'83, M'85, SM'94) received the B.S.E.E. degree from the Indian Institute of Science, Bangalore, India, the M.S.E.E. degree from North Carolina State University, Raleigh, and the Ph.D. degree with a concentration in electric power engineering from Virginia Polytechnic Institute and State University, Blacksburg. He is a Staff Engineer with the Protective Relays Group, Cooper Power Systems, South Milwaukee, WI. He is responsible for relay applications for the Cooper line of relays and relay settings for power system equipment. He is the recipient of the 2000 IEEE PES Chicago Chapter Outstanding Engineer Award. He is a member of the Substation Subcommittee of the IEEE Power System Relaying Committee. Dr. Chaudhary is also a member of the Technical Committee of the International Power Systems Transients Conferences 1999, 2001, and 2003. His previous experience has included Sargent & Lundy consulting engineers (1991-1998) and Bharat Heavy Electricals Limited, India (1979-1983).

## VIII. BIOGRAPHIES



Amit Raje did his B.Tech in Electrical Engineering from the Indian Institute of Technology, (Mumbai, Maharashtra, India, '91-'95). He then did his M.S. in Electrical Engineering from the University of Minnesota, (Minneapolis, MN, USA, '95-'96) in Power Systems. He has worked as a Senior Engineer with Open Systems International, (Plymouth, MN, USA) during '96-'97 in the field of Energy Management Systems. Since 1997, he has headed the R&D division of Aartech Solonics (Bhopal, MP, India) and has focused on the research, development, testing, engineering and commissioning of Fast Bus Transfer Systems for the utility and process industries. In April 2007, he succeeded his father, Anil Raje – Original Pioneer of Fast Bus Transfer Systems in India – as Managing Director of the company. He is a professional IEEE member and has authored several international conference technical papers in the past. His other field of work is related to development of tamper proof microprocessor based energy meters, and has filed a patent in this regard. His research interests are focused on the development of innovative, embedded and integrated power system solutions to consumers, utilities and industries.

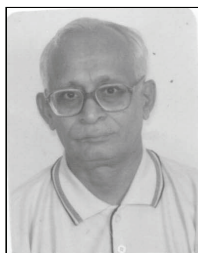

**Anil Raje** is currently the Chairman of Aartech Solonics Limited (Bhopal, Madhya Pradesh, India). He received the B.E. in Electrical Engineering from M.A.C.T. (Maulana Azad College of Technology, now known as M.A.N.I.T. Maulana Azad National Institute of Technology) ; Bhopal, Madhya Pradesh, India, '62-'66). He started his career with the switchgear division of Larsen & Toubro (Bombay, Maharashtra, India) quickly switching to an entrepreneurial career in 1971. In 1988, he founded Aartech Solonics Limited for the manufacturing of application engineered control-gear equipments and system solutions. Herein, he pioneered the design, development and implementation of the first generation Fast Bus Transfer Systems for thermal power stations and process industries; now widely used in India. Currently, his main technical interests and activities